

NEW! 25-YEAR LINEAR
PERFORMANCE GUARANTEE
AND 5-YEAR EXTENDED
PRODUCT WARRANTY*

Length 65.94 in (1675 mm)
Width 39.41 in (1001 mm)
Height 1.34 in (34 mm)
Weight 48.5 lbs (22 kg)
Frame Aluminum

Sunmodule⁺

SW 245 MONO



World-class quality

SolarWorld products are manufactured in state-of-the-art factories according to strict German and US quality, labor and environmental standards.

Award-winning products

SolarWorld modules were ranked number one in two consecutive tests carried out by the Photon trade magazine in 2008 and 2009 with up to 12% more yield.

SolarWorld Plus-Sorting

Plus-Sorting guarantees the highest efficiency of the installation. SolarWorld only delivers modules that have greater than or equal to the nameplate rated power.

25-year Linear Performance Guarantee*

SolarWorld guarantees, over 25 years, that the modules' performance will not decrease by more than 0.7% per year – a distinct added value compared to the two-tiered guarantees usual in the industry.

*according to the SolarWorld service certificate valid at the time of purchase
www.solarworld-global.com/service-certificate



We turn sunlight into power.

Sunmodule⁺

SW 245 MONO

PERFORMANCE UNDER STANDARD TEST CONDITIONS (STC*)

		SW 245
Maximum power	P_{max}	245 Wp
Open circuit voltage	V_{oc}	37.7 V
Maximum power point voltage	V_{mpp}	30.8 V
Short-circuit current	I_{sc}	8.25 A
Maximum power point current	I_{mpp}	7.96 A

*STC: 1000W/m², 25°C, AM 1.5

PERFORMANCE AT 800 W/ M², NOCT, AM 1.5

		SW 245
Maximum power	P_{max}	179 Wp
Open circuit voltage	V_{oc}	34.4 V
Maximum power point voltage	V_{mpp}	28.1 V
Short-circuit current	I_{sc}	6.65 A
Maximum power point current	I_{mpp}	6.37 A

Minor reduction in efficiency under partial load conditions at 25°C: at 220 W/m², 95% (+/-3%) of the STC efficiency (1000 W/m²) is achieved.

COMPONENT MATERIALS

Cells per module	60
Cell type	Monocrystalline Silicon
Cell dimensions	156 mm x 156 mm
Front	tempered glass (EN12150)

SYSTEM INTEGRATION PARAMETERS

Maximum system voltage SC II	1000 V
Maximum system voltage USA NEC	600 V
Maximum reverse current	16 A
Increased snowload acc. to IEC 61215	5.4 kN/m ²

THERMAL CHARACTERISTICS

NOCT	47 °C
TC I_{sc}	0.042 %/°C
TC V_{oc}	-0.33 %/°C
TC P_{mpp}	-0.45 %/°C

ADDITIONAL DATA

PTC rating	219.6 W
Junction box	IP65
Connector	MC4
Module efficiency	14.6 %
SolarWorld Plus-Sorting*	$P_{Flash} \geq P_{max}$
Power tolerance*	+/- 3 %

*Only modules with flash-tested power $\geq P_{max}$ are delivered.
Linear warranty guarantees Year 1 module output to $\geq 97\%$ of P_{max}

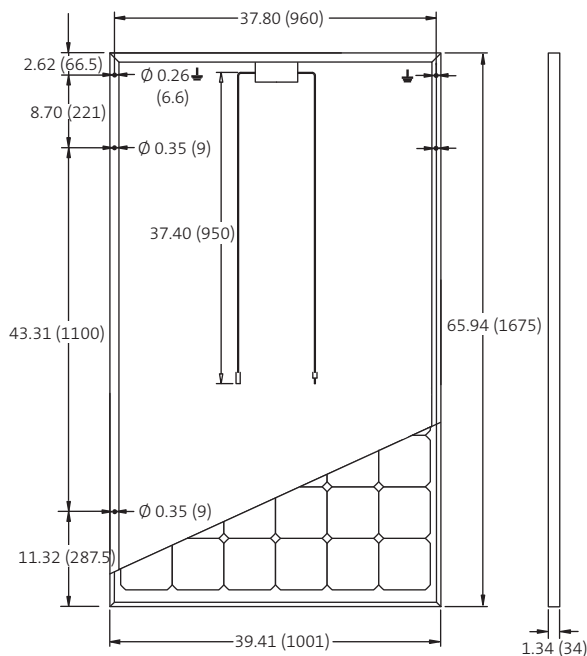

- Qualified, IEC 61215
- Safety tested, IEC 61730
- Periodic Inspection



CORROSIVE GAS (NH₃) RESISTANT



SolarWorld AG reserves the right to make specification changes without notice.
This data sheet complies with the requirements of EN 50380.
Sunmodule panels are manufactured in ISO 9001:2000 certified facilities